

SHARP



DL-ET01E-S 10,000 lm
DL-ET02E-S 5,000 lm

BRIGHT LED STREET LIGHT

ECONOMY

Energy saving more than 70% less power consumption than traditional street lights.

BRIGHTNESS

Ultra bright, cool white light close to daylight quality, LED fixture provides bright white light which improves color rendering and improves night visibility to 300% over traditional light sources.

GREEN LIGHT SOURCE

LED light eliminates glare, light trespass and sky glow, No light pollution, No Insect attracted.

EXTREMELY LONG LIFE

LED Street light are rated at more than 60,000 hours which translates to more than 10 years of maintenance free product life.



Bug Free



No Mercury



Bright Color



Long Lifetime



Low Wattage



Energy Saving



Eco Friendly

VERTICAL LUMINOUS INTENSITY DISTRIBUTION CURVE

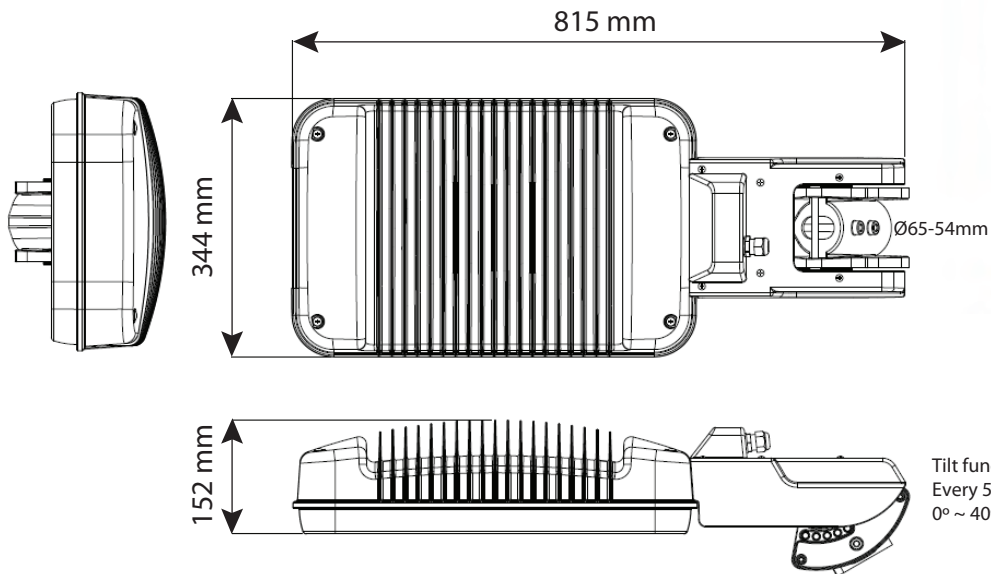
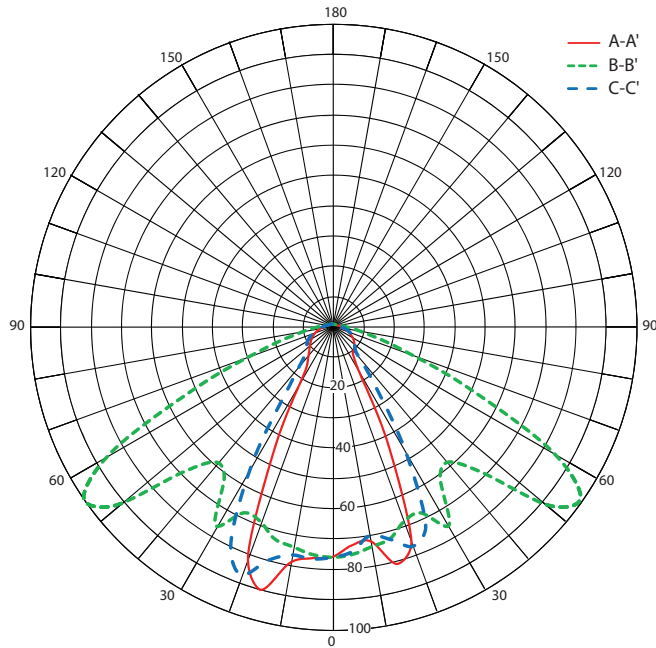

Parameter	DL-ET02E-S	DL-ET01E-S
Light source	White LED	White LED
Input supply Voltage	AC10 0V- 240V 50/60Hz	AC10 0V- 240V 50/60Hz
Power Factor	95%	95%
Power Consumption	87.2 W	154W
Luminous flux (Original Flux)	5,000lm	10,000lm
Beam angle	130°	130°
CCT	5,600K (Cool White)	5,600K (Cool White)
CRI	70 (Daylight)	70 (Daylight)
Ref.life time	60,000h	60,000h
Operation temp	-30°C ~ 40°C	-30°C ~ 40°C
IP Rating	IP65	IP65
Dimensions	W344mm x D815mm x H152mm	W344mm x D815mm x H152mm
Street pole φ	φ 65 - 54mm	φ 65 - 54mm
Lamp tilt angle	0-40° Horizontal insertion only	0-40° Horizontal insertion only
Life Time	60,000 Hours (to reach 70%)	60,000 Hours (to reach 70%)
Weight	16kg	16kg
Installation Height	Up to 10m above ground	Up to 10m above ground
Installation Pitch	Every 30 - 40m	Every 30 - 40m
Body Material/Colour	Die-cast Aluminium/Silver	Die-cast Aluminium/Silver
Glass Cover Material	Tempered Glass	Tempered Glass

Specifications are subject to change without notice